

## A MESSAGE TO OUR CUSTOMERS









---

Thank you for selecting the Professional Charcoal Grill. We have worked hand in hand to create a product that meets our exacting standards and will provide years of pleasurable, outdoor grilling.

Because the grill has features not found on any other, we recommend that you read this entire booklet before your first use. Then, keep it in a handy place as it has answers to many questions that may arise during use.

Please contact us at any time if we can help you with questions about parts and use **(714) 373-5398**

## Table of Contents

	<b>SAFETY PRACTICES / PRECAUTIONS</b>	<b>2</b>
	<b>GRILL FEATURES</b>	<b>3</b>
	<b>ASSEMBLY OF CHARCOAL GRILL</b>	<b>45</b>
	<b>ASSEMBLY STEPS</b>	<b>6-10</b>
	<b>BUILD IN CLEARANCES</b>	<b>11-12</b>
	<b>USING YOUR GRILL</b>	<b>13-14</b>
	<b>CARE AND STORAGE</b>	<b>15</b>
	<b>WARRANTY</b>	<b>15</b>
	<b>GRILL RECIPES</b>	<b>16-17</b>

## Safety Practices & Precautions

### Safety Practices to Avoid Injury:

***The Charcoal Grill is for outdoor use only. Do not use the charcoal grill indoors as this can be fatal.***

When properly cared for, your grill will give safe, reliable service for many years. However, extreme care must be used since the grill produces intense heat and can increase accident potential. When using this appliance basic safety practices must be followed, including the following:

- Read this Care and Use Guide carefully and completely before using your grill to reduce the risk of fire, burn hazard or other injury.
- Do not use flammable materials and fluids such as gasoline, alcohol, diesel fuel, or kerosene to light or relight fires. Keep the grill away from these materials when lit.
- Exercise the same precautions you would with an open fire.
- ***Children should not be left alone or unattended in an area where the grill is being used. Never allow them to sit, stand or play on or around the grill at any time. When in use, portions of the grill get hot enough to cause severe burns.***
- Do not wear flammable or loose fitting clothing such as nylon when using the Charcoal Grill.
- Do not burn trash, leaves, paper, cardboard, or plywood in the Charcoal Grill.
- Do not store the Charcoal Grill with ashes or combustible materials inside. Do not store the Charcoal Grill until the fire is completely out and the Charcoal Grill is cold.
- Use BBQ mitts when handling the Charcoal Grill and tending the fire.
- Do not move the Charcoal Grill while in use.
- Keep all bolts, nuts, and screws tight to be sure Charcoal Grill is in safe working condition.
- Do not use charcoal for indoor cooking or heating. Toxic carbon monoxide fumes may collect and cause death.
- Always use an oven mitt to protect hand when opening the grill lid and only do so slowly, to allow heat and steam to escape. Never lean over an open grill.

**Grill Features**

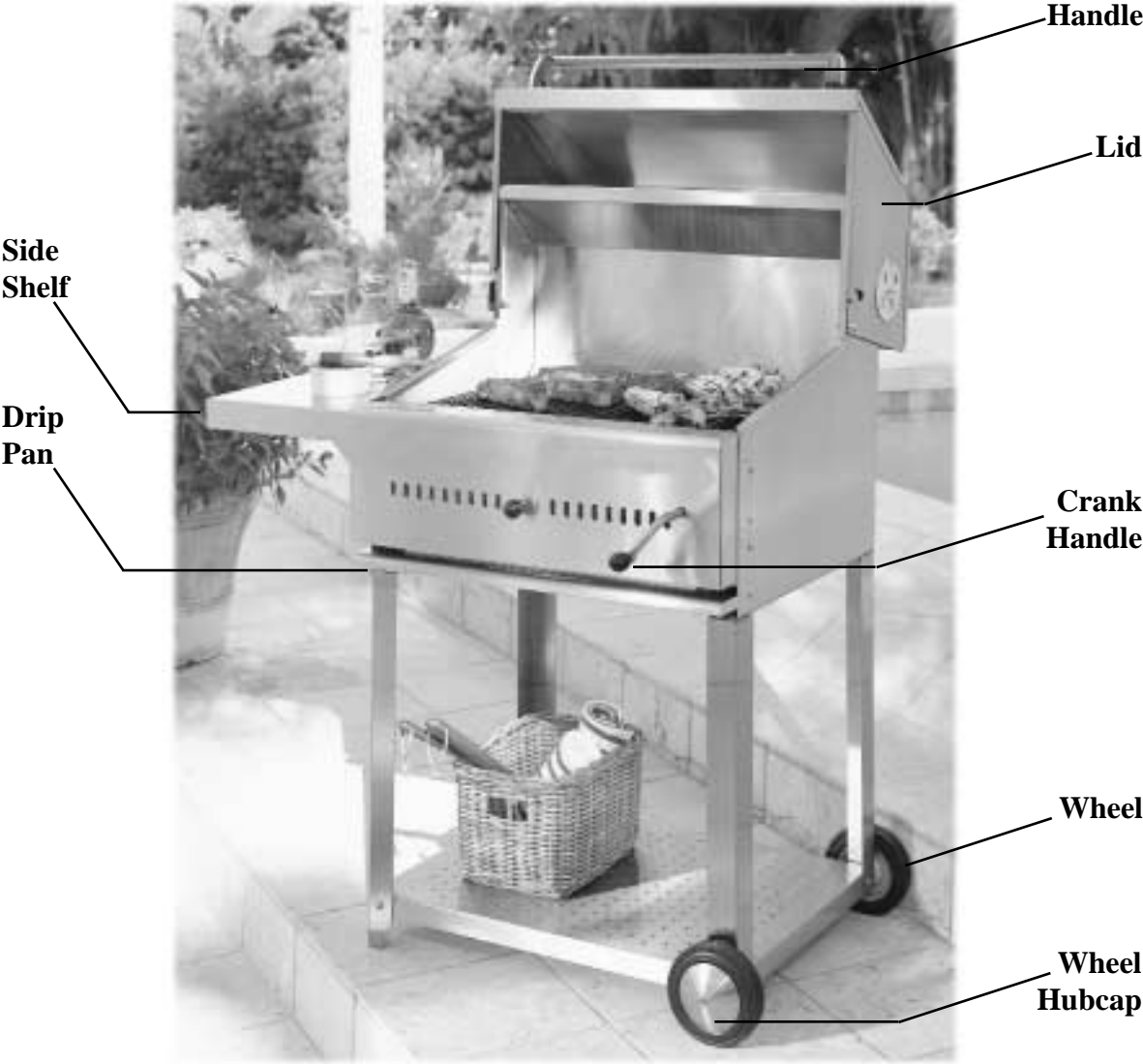

## Assembly of Your Charcoal Grill

**Before Use:** Read all instructions in this guide. Check to make sure all parts are included in your Professional Charcoal Grill before assembling unit. Place the shipping carton on the ground while assembling your Grill to prevent scratching or damaging your Professional Charcoal Grill.

### Included Parts:

A) The parts needed for quick and easy assembly of your Charcoal Grill are included as shown.

- A) Wheel Axle Rod (1)
- B) Base Wheel (2)
- C) Wheel Hubcap (2)
- D) Crank Handle (1)
- E) Grate (2)
- F) Back Leg (2)
- G) Front Leg (2)
- H) Leg Supports (2)
- I) Bottom Shelf (1)
- J) Side Shelf (1)

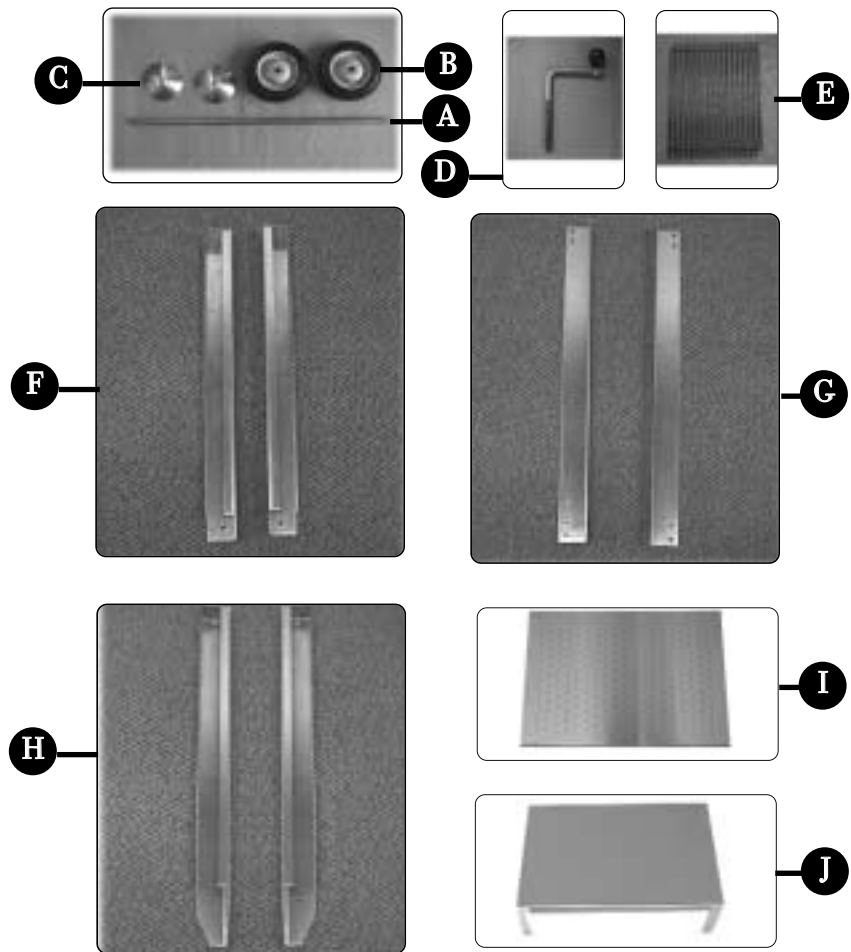

## Assembly of Your Charcoal Grill

### Hardware Included:

- A) (4) 1/4-20 X 3/4 Hex Bolt
- B) (8) 1/4-20 X 1/2 Hex Bolt
- C) (14) Carriage Bolts
- D) (4) 1/4 Aluminum Spacers
- E) (14) 1/4-20 Hex Nuts
- F) (2) Flat Head 8-32 x 3/4 Screw
- G) (2) Wheel Nuts
- H) (4) Washers

### Tools Needed:

- 7/16 Socket or Wrench
- 3" Extension
- Phillips Head Screwdriver

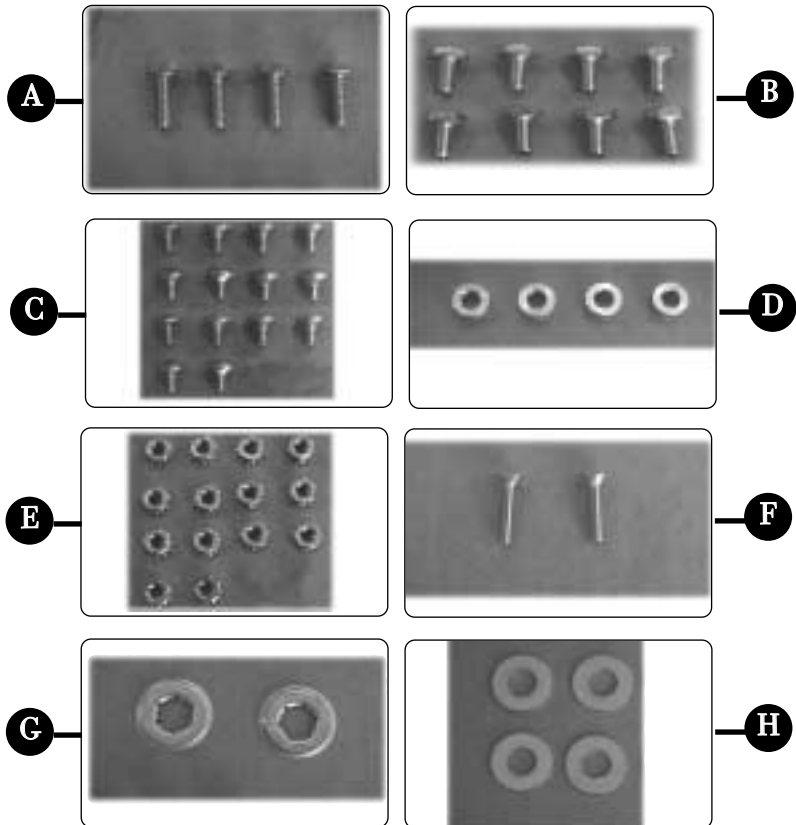

## Assembly Steps

### Step One:

#### A) *Front Leg Assembly:*

Attach front leg and leg support, finger tight as shown. Using the carriage bolts and 1/4-20 hex nuts.



**B)** Tighten with a 7/16 socket or wrench, be careful not to over-tighten.

### Step Two:

#### A) *Back Leg Assembly:*

Attach back leg and leg support (following step one), finger tight as shown. Using the carriage bolts and 1/4-20 hex nuts.

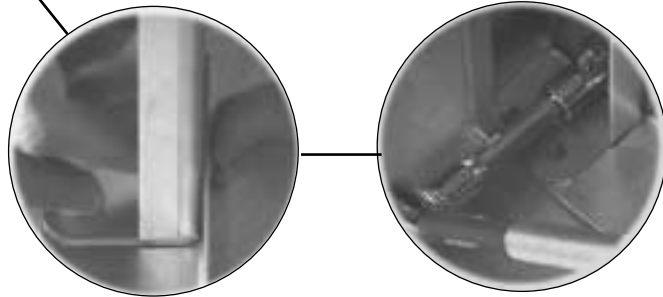

**B)** Tighten with a 7/16 socket or wrench, be careful not to over-tighten.

Front Leg Assembly

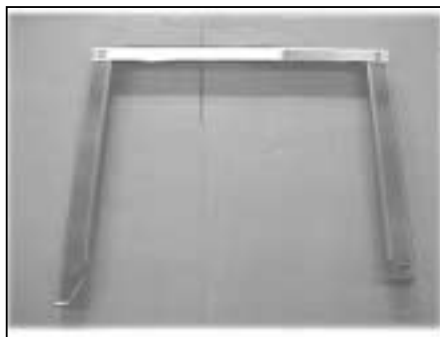

Back Leg Assembly



## Assembly Steps

### Step Three:

**A)** Attach back leg assembly to bottom shelf as shown. Using the carriage bolts and 1/4-20 hex nuts.

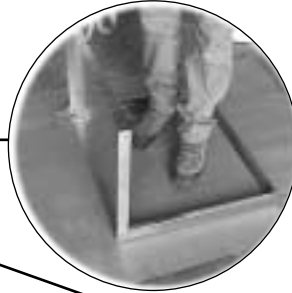

**B)** Slide carriage bolt through each square hole finger tight with 1/4-20 hex nuts. Tighten with a 7/16 socket or wrench.

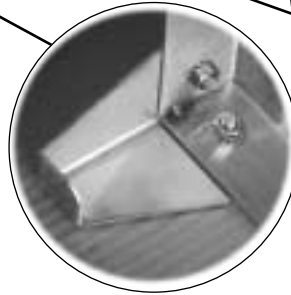

### Step Four:

**A)** Turn both sides on end and attach front leg assembly to bottom shelf as shown. Use the carriage bolts and 1/4-20 hex nuts packed in your hardware bag.

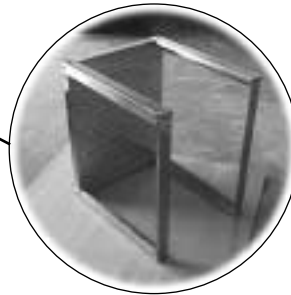

**B)** Slide carriage bolt through each square hole finger tight with 1/4-20 hex nuts. Tighten with a 7/16 socket or wrench.

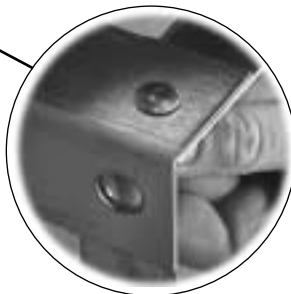

## Assembly Steps

### Step Five:

**A)** Grasp axle rod with one hand and slide through holes at bottom of cart.

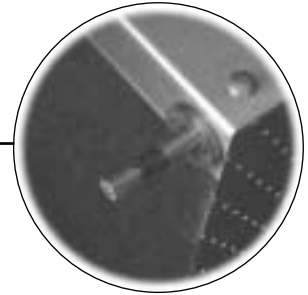

**B)** Place two washers at each end of axle rod before attaching wheel.



**C)** While holding axle rod, slide wheel over axle rod. Use wheel lock nuts provided to lock wheel in place.

**D)** To attach wheel hubcap place hubcap over wheel and, using screws provided, tighten with a phillips head screwdriver.

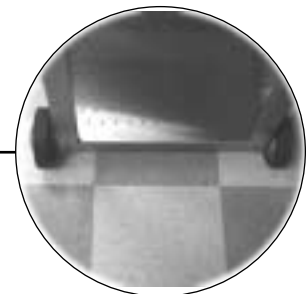
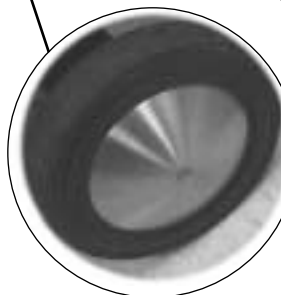
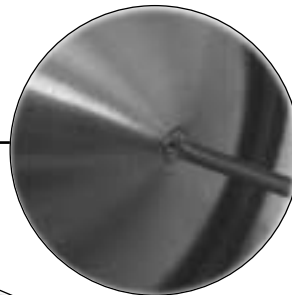

## Assembly Steps

### Step Six:

**A)** Before attaching grill head remove cooking grates, and drip pan from grill. To attach grill head to cart you will need some help to prevent injury. ***Make sure that there is someone to stabilize grill head while tightening hex bolts and keps nut.***

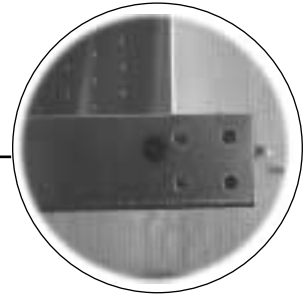

**B)** Place grill head on cart. Attach head using (2) 1/4-20 X 1/2 hex bolts in each corner, (quickly tighten bolts by hand to make sure grill head does not slide off cart). Using a 7/16 socket or wrench, tighten all four corners.



### Step Seven:

**A)** To assembly side shelf use 1/4-20 x 3/4 hex bolts and aluminum spacers provided.

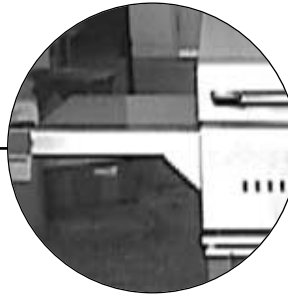

**B)** Grasp side shelf with one hand. With other hand thread hex bolts through holes on left side of grill head as shown. Tighten with 7/16 socket or wrench.

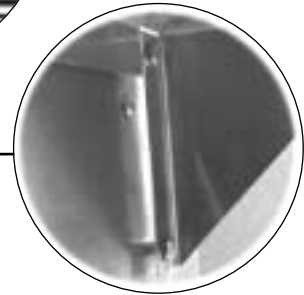

## Assembly Steps

### Step Eight:

**A)** Attach crank handle by threading through hole on right side of front panel.

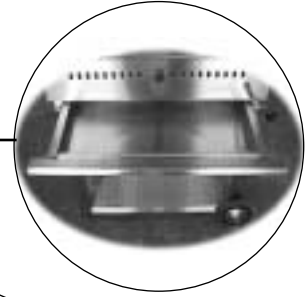
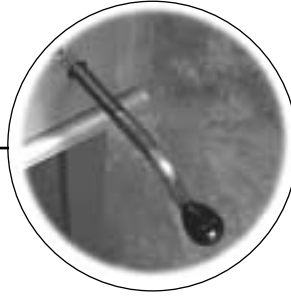

**B)** Before cooking make sure drip pan and grates are in place as shown.

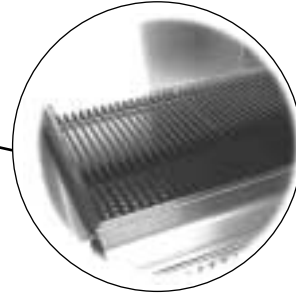

## Built-in Clearances

### ***Clearance for combustible construction:***

A minimum of 12" from the back of the grill to combustible construction is required for the purpose of allowing the lid to open fully.

### ***Clearance for non-combustible construction:***

A minimum of 5" from the back of the grill to non-combustible construction is required for the purpose of allowing the lid to open fully.

For proper rotisserie functioning, allow at least 9" clearance on either side to non-combustible construction above the cooking surface, for motor and skewer handle clearance.

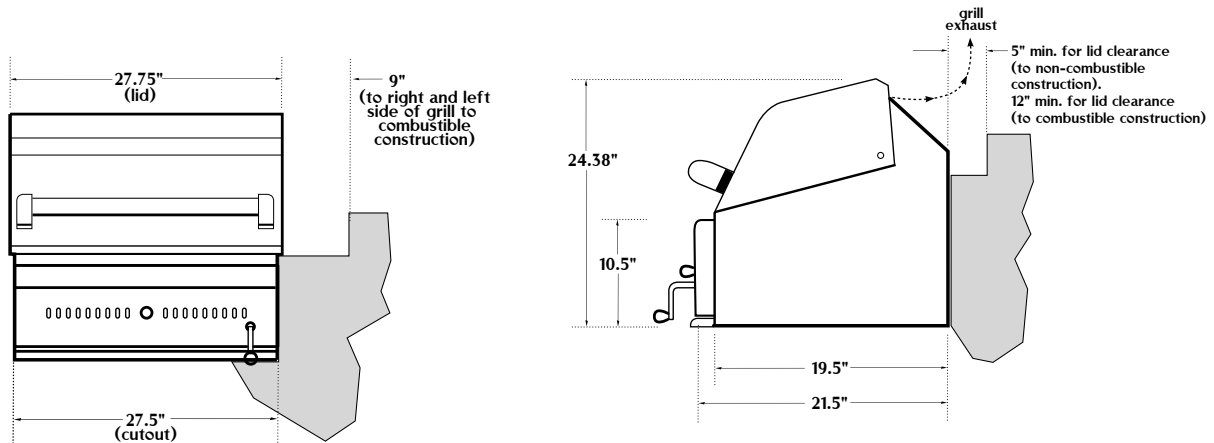

## Built-in Clearances

The Professional Charcoal Grill is designed for easy placement into masonry enclosures. Grill must be supported (both for combustible and non-combustible) by a solid bottom deck. The supporting ledges or deck must be level and flat. The counter should also be level.

If the Professional Charcoal Grill is to be placed into a combustible enclosure, an approved insulated jacket is necessary and is available from your dealer. Use only the manufacturer's insulated jacket which has specifically been designed and tested for this purpose. Do not build the Professional Charcoal Grill under overhead unprotected combustible construction.

When determining a suitable location take into account concerns such as exposure to wind, proximity to traffic paths. Locate the grill only in a well ventilated area. Never locate the grill in a building, garage, breezeway, shed or other such enclosed areas without an approved ventilation system.

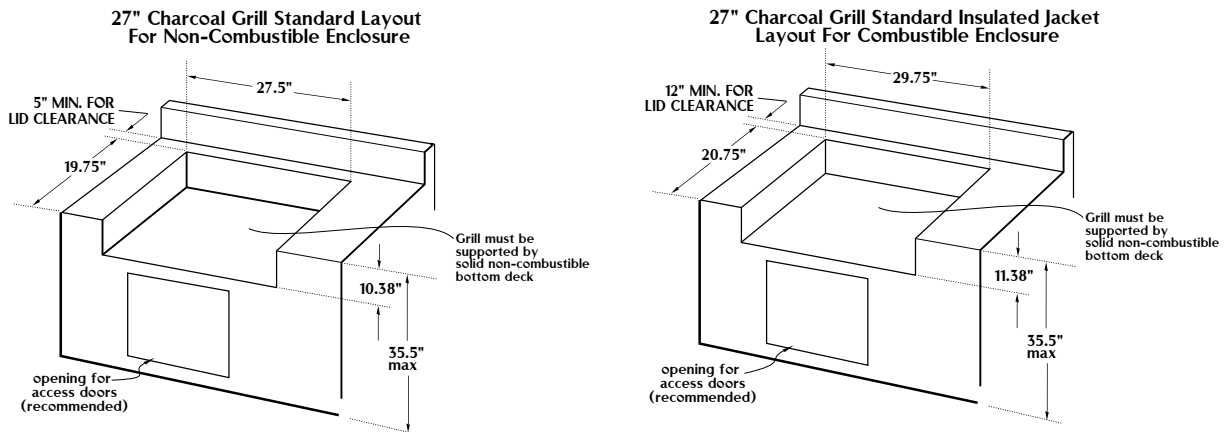

## Using Your Grill



**WARNING:** *Keep small children away from open flames or while cooking to prevent injury.*

### Lighting Instructions:

Use a high quality hardwood charcoal to make sure you get a good fire. Charcoal briquettes made from maple, oak, birch, or elm woods will burn clean with very little smoke and unpleasant odors.

Open the hood and all the vents, remove the cooking grates. Place charcoal on the fire grate at the bottom of grill, arrange charcoal in a pyramid shaped stack, add charcoal lighting fluid according to manufacturer's instructions. Let stand for about a minute to let fluid soak into charcoal, and carefully light the charcoal and let charcoal burn for approx. 15 to 20 minutes or until it is all covered with a light gray ash.

### Grilling:

Use long-handled tongs to arrange the charcoal in a checkerboard pattern. Leave about one-half inch of space between each piece of charcoal. This will help you to avoid flare-up from the meat drippings and will give you the even heat that is best for grilling

### Indirect cooking:

For roasting large pieces of meat, use a roasting pan or use aluminum foil, just crease the foil to stand up about an inch on all sides and pinch the corners firmly to stop the grease from leaking out. Carefully place pan on bottom of grid and surround with charcoal, most indirect cooking takes quite a bit of time.

## Using Your Grill

### **Charcoal Basket:**

For slower cooking turn crank counterclockwise to lower the charcoal basket for faster cooking, raise charcoal basket by turning crank clockwise.

Use the highest position for searing steaks and hamburgers or whenever more heat is needed. Foods cook very fast at this position, so be careful not to over cook or burn meat. Lower the basket halfway for meats, such as pork and chicken, that have to be cooked a longer period of time. *At lowest setting make sure not to over turn as crank handle may fall or become loose.*

### **Tilt away Hood:**

Leave the hood open for “Texas Style” open air grilling. Close the hood for “Smoker” cooking or whenever you want to hold in all the heat.

### **Adjustable Draft:**

Leave the hood open for the most heat. Close the lid part way to lower the heat, it may take a few moments for the charcoal to react to the vent adjustments. If you need to change the cooking speed after you have closed the lid, raise or lower the charcoal basket.

### **Flame-Up:**

Close lid for a least one minute to stop flame-up. You do not need to use water.

## Care & Storage

### Cleaning Stainless Steel:

To prevent burns or injury make sure grill is completely cool before cleaning. The Professional Charcoal Grill is made from non-rusting and non-magnetic stainless steel. After initial usage, areas of the grill may discolor from the grills heat. This is normal.

There are many different stainless steel cleaners available. Always use the mildest cleaning procedure first, and always scrub in the direction of the grain. Soapy water should be sufficient for most cleaning.

**Note:** Do not use oven cleaners or abrasive cleaner on enameled surfaces as they may damage the finish.

### Removal of Ashes:

Remove the ashes as soon as possible after each time you cook. Wait until the charcoal has cooled, slide out the drip pan and pour out the ashes. You can save the larger pieces of charcoal for use next time you cook. Use a garden hose to wash out accumulated grease and ashes, let the drip pan dry before putting it back in your grill.

### Cooking grates:

Use solution of detergent and hot water just as you would for any cooking equipment. A stiff brush may be helpful in removing heavy deposits of grease and food.

### Body and Lid:

Wipe the inside of the hood and body with a cloth dampened in a solution of detergent and hot water. The outside surfaces can be cleaned the same way. Wipe all areas dry before storing.

### Storage:

For your safety, before storing your charcoal grill (*make sure unit is cool and embers are completely extinguished*).

### Warranty:

All stainless steel Five (5) year warranty on all stainless steel parts.

Three (3) year warranty on all porcelain enameled parts.

## Grill Recipes

### Garlic Shrimp...

This recipe could serve as an appetizer or a main dish depending on the size of the shrimp. Thread shrimp on skewers so they will not fall through the grates, or grill them on aluminum foil. Adjust charcoal basket to a medium position and cook for about 10 minutes.

**12 oz. frozen peeled and deveined shrimp**  
**1/2 C butter or margarine**  
**4 cloves garlic, sliced**

**1 Tbl. chopped parsley**  
**salt and pepper to taste**  
**1/4 C fresh lemon juice**

Cook garlic in butter for 2 to 3 minutes; add remaining ingredients except shrimp and heat until blended. Put shrimp in shallow dish; pour marinade over shrimp and let stand for 1 hour. Thread shrimp on metal skewers and cook for 5 minutes per side. Turn and baste occasionally. Makes 4 servings.

### Island Steak...

Combine all ingredients except the steak (use garlic press to get celery juice). Marinate the steaks with this mixture for 30 minutes only. Drain the steaks and sear each side one minute with grates in lowest position over moderate fire. Raise grates to a medium position and cook to taste. Turn steaks twice.

**6 Ribeye Steaks about 1" thick**  
**1 C soy sauce**  
**1 clove garlic crushed**  
**1/4 C salad oil**

**Juice from small piece celery**  
**(about 1/4 medium size stalk).**

## Grill Recipes

### Smokey Mountain Spareribs...

Combine marinade ingredients and brush onto ribs. Use soaked wood chips and the indirect cooking method shown. Place meat bone side down on grates. Over moderate fire cook 1 1/2-2 hours with lid closed or until done. Add wood chips and charcoal if necessary to maintain smoke and even heat. Turn and baste the ribs every 10 minutes during the last 30-40 minutes of cooking. 6 servings

**1/2 C worcestershire sauce**  
**1/2 C vinegar**  
**2 racks spareribs (about 6 Lbs.)**

**1/2 C margarine, melted**  
**1/4 Tsp. tabasco**  
**1/2 Tsp. salt**

### Barbecued Pork...

Thicker pork cuts should be cooked with the grates in the highest position. The secret is to brown the meat, but not to grill it so long that it becomes dry. Cook for about 20-30 minutes.

**4 pork steaks or chops 1/2 thick**  
**1 beef bouillon cube**  
**1 Tsp. ground ginger**  
**1/4 C molasses**

**1/4 C soy sauce**  
**2 Tsp. salt**  
**2 Tbsps. hot water**

Dissolve bouillon cube in hot water, add remaining 4 ingredients and blend. Put meat in dish and pour marinade over meat, cover and refrigerate 2 hours turning occasionally. Remove pork from marinade, drain well and grill for 10-15 minutes per side, basting occasionally with remaining marinade. Makes 4 servings.

**As product improvement  
is an ongoing process, we  
reserve the right to  
change specifications or  
design without notice.**

**Litho in USA 5-2000  
Part No. 110036**

---

# **PROFESSIONAL CHARCOAL GRILL**

## **USE & CARE MANUAL**

